

Wall-mounted/post-mounted AC EV charger

RACE

Series AC Charger

User Manual



+86-400-826-0298
contact@pingalax.com
www.pingalax.com
No.1 Hongyu Avenue, Bishan District,
Chongqing, China.

- Please read this manual carefully before installation and use, and observe the warnings and cautions marked in this product manual.
- Please keep this manual properly.

Thank you for choosing RACE series AC EV chargers (hereinafter referred to as EV charger). Please read this user manual thoroughly before using the product, and please keep this manual properly.

EV chargers are charging equipment to meet the charging needs of electric vehicles, and can be installed in garages, parking lots, etc. Because of the complicated structure of high-voltage, low-voltage wires and electronic components in the product, please do not disassemble or modify the wires or electronic components by yourself, and the resulting damages are not under our company's warranty, the company will not be held responsible for the resulting personal injury.

The purpose of this manual is to help you use the product correctly. It does not represent any description of the production of this product. For product configuration, please refer to the related contract (if any), or consult the seller who sold the product to you. The pictures in this manual are for reference only, if there is any discrepancy between the pictures and the actual product, the actual product shall prevail.

CONTENTS

01	Safety Information	02
02	Parameter and Specification	04
03	Installation	08
04	Installation (Wall-mounted)	12
05	Installation (Post-mounted)	16
06	Installation (Cable connection)	21
07	How to Use the Charger	27
08	Trouble-shooting and Maintenance	29
09	Reliability Terms	30
10	Product Warranty	32

Safety Information

Product Introduction

RACE series AC EV chargers are electric vehicle smart chargers independently developed by PINGALAX. It is used with the on-board charger to charge electric vehicles. This series of products are easy to install, small in size, easy to operate, and stylish in appearance. It is suitable for various open-air and underground parking lots such as public parking lots, residential community and enterprise parking lots, etc.

Product Specification

All specifications and descriptions in this manual have been verified for accuracy at the time this manual was printed. At the same time, Pingalax aims for continuous improvement and we reserve the right to make changes at any time.

Error and Omission

For any error or omission, or feedback or suggestion about this manual, please email: contact@pingalax.com.

Copyright

All copyrights and other intellectual property rights in this article are owned by PINGALAX and its licensors. Without the prior written permission of PINGALAX and its licensors, the materials shall not be copied, reproduced or modified in whole or in part. Additional information is available upon request.

Safety Information



Warning

WARNING: Before using this product, please read the instructions thoroughly.
WARNING: Supervise when children are in the presence of using this equipment.
WARNING: The EV charger must be grounded through permanent wiring systems or equipment grounding conductors.
WARNING: Do not install or use the EV charger near flammable, explosive, rough or combustible materials, chemicals or steam.
WARNING: Before installing or cleaning the EV charger, please turn off the input power on the circuit breaker.
WARNING: Use the EV charger only in accordance with the specified operating parameters.
WARNING: Do not spray water or other liquids directly onto the control box. Do not spray water on the charging connector or immerse the charging connector in liquid. Please put the charging connector into the charging holder to avoid contamination or moisture.
WARNING: Stop using or do not use the EV charger if it is defective, cracked, worn, damaged, or inoperable.
WARNING: Do not attempt to disassemble, repair or modify the EV charger. The charger is not a user-serviceable device. For any repair, please contact us.
WARNING: Be careful when transporting the charger. Do not force or impact or pull, twist, tangle, drag or step on the charger to prevent damages to the charger and the components.
WARNING: Do not touch the end of the charger with your fingers or sharp metal objects (such as wires, tools or needles).
WARNING: Do not forcibly fold or apply pressure to any part of the charger or use sharp objects to damage it.
WARNING: Do not insert foreign objects into any part of the charger.
WARNING: Using of EV charger can interfere with or damage the operation of medical or implanted electronic devices, such as implanted cardiac pacemakers or implanted cardioverter-defibrillators, please consult the manufacturer of such electronic devices before using the EV chargers.



Precautions

WARNING: Power cables must be used as specified.
WARNING: Do not use private generators as a charging source.
WARNING: Improper installation and testing of the charger can cause potential damage to the vehicle battery and/or the charger itself.
WARNING: Do not use the charger at a temperature beyond the working range of -30°C to +50°C.



Notes

NOTE: Make sure that the cables of the charger are properly placed so that it will not be stepped on, crushed, entangled, damaged or compressed.
NOTE: Do not use cleaning agents to clean any components of the charger. The exterior of the charger, the charging cable and ends of the charger should be wiped regularly with a clean dry cloth to remove dirt and dust.
NOTE: Prevent the circuit board or components from damage during installation.
NOTE: adaptors or conversion adapters are not allowed to be used cord extension sets are not allowed to be used.

Parameter and Specification

Model number

PCAC-J4-EU7/230

- Maximum Output Voltage: 230V
- Maximum output power: 7kW
- Execution standard: European standard
- Box type: J-AC EV charger
- The number is the serial number of the charger
- Charging type: AC- alternating current
- Company name: PINGALAX

Technical specifications

Item	Value
Output Rating	7kW
Output Voltage	230VAC±15%
Max Output Current	32A
Power Conversion Efficiency	≥99%
Connector Options	IEC62196-2, Type 2
Cable Length	16 feet (5m)
Input Voltage	230VAC±15%
Frequency	50/60Hz
Power Factor	>0.99
Wiring	L+N+PE
Display	LED
Communication	RJ45, 4G, Wi-Fi
Communication Protocol	OCPP 1.6J, 2.0.1J
Bluetooth/Wi-Fi	Bluetooth / Wi-Fi 2.4G
Safety Features	Over Current, Over Voltage, Under Voltage, Short Circuit, Over Temperature Protections, Reset Function
RCD	Type A+6mA
Power Measurement Accuracy	±1%
Access Control	App/RFID/Plug & Play
RFID	ISO/IEC 14443A/B, Mifare
Safety Compliance	CE, CB

Parameter and Specification

Other Functions	OTA
Dimensions	208mm×153mm×418mm
Net Weight	≤5kg
Protection Degrees	IP54
Operating Temperature	-30°C~50°C
Storage Temperature	-40°C~70°C
Power Cooling	Natural-air-cooled
Working/Storage Humidity	≤95%
Altitude	≤2000m
Noise	≤40dB
Mounting Options	post-mounted\Wall-mounted
OEM Customize Options	Nameplate, Color, User manual, Length of charging cable



Notes

The following is the wireless operating frequency range, declared maximum transmitting power and antenna gain supported by this product.

Intended Use / Category	RF output power	Frequency range (MHz)	Modulation	Antenna gain
2.4G Wi-Fi(802.11b)	18.55dBm(EIRP)	2412-2472MHz	DSSS	3.42dBi
2.4G Wi-Fi(802.11g/n)	19.97dBm(EIRP)	2412-2472MHz	OFDM	3.42dBi
Bluetooth (BLE)	1.76dBm (EIRP)	2402-2480MHz	GFSK	3.42dBi

4G	Operating Frequency	Band	Transmit power	Transmit	Receive	Antenna gain
		LTE Band 1	22.4dBm	1920~1980MHz	2110 ~2170MHz	4.6dBi
		LTE Band 3	22.9dBm	1710~1785MHz	1805 ~1880MHz	4.6dBi
		LTE Band 7	22.5dBm	2500~2570MHz	2620~2690MHz	4.6dBi
		LTE Band 8	22.8dBm	880~ 915MHz	925 ~960MHz	1.8dBi
		LTE Band 20	22.6dBm	832~862MHz	791~821MHz	1.8dBi
		LTE Band 28	22.5dBm	703~748MHz	758~803MHz	1.8dBi
		RFID	1.64dBuA/m @3m	13.56MHz		0dBi

Production principle

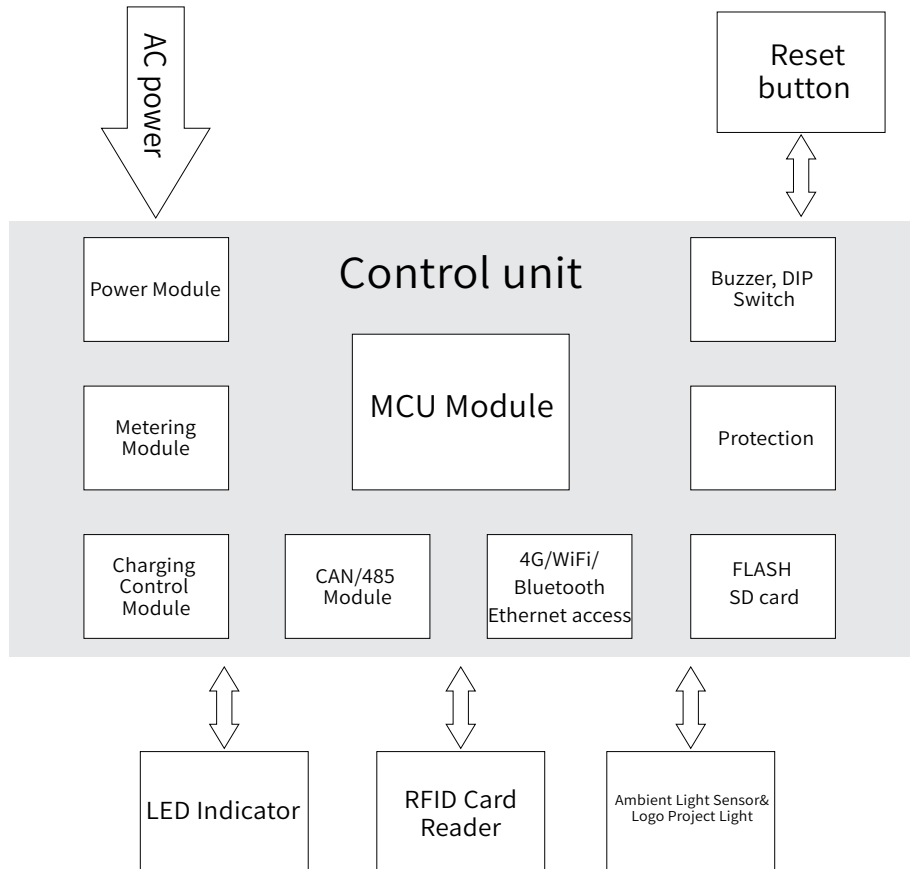

Wall-mounted/post-mounted AC EV charger

RACE

Series AC Charger

Installation Instruction

Installation

Charger & Installation Dimension

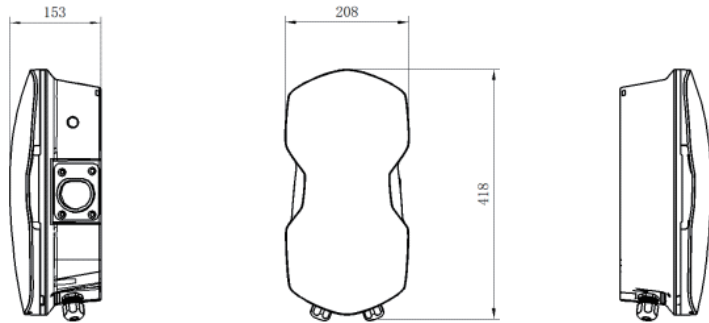

Safety regulations

The working voltage and current of the charging system is very high. In order to ensure personal safety, the following regulations should be followed at all times:

- (1) Only personnel who have been trained and have sufficient knowledge on the charging system (personnel with an electrician operation certificate) can install the charging system. During the installation, always abide by the safety precautions and local safety regulations.
- (2) If operate the inside of the charger, make sure that the charging system is not on charge. The input of the charger must be disconnected.
- (3) Protective measures should be taken and the power distribution cables should be reasonably routed to avoid touching when operating power equipment.
- (4) In order to ensure safe operation of the charger, it is recommended to use a leakage protection circuit breaker.
- (5) The charger should be permanently grounded. Ground the equipment first before installing. When removing the equipment, the grounding conductor must be removed last. It is strictly forbidden to operate the equipment when the grounding conductor is not installed.

Installation

Minimum requirements

Requirements for installing of EV chargers:

- Calculate the existing electrical load to determine the maximum operating current.
- Calculate the inlet cable length to ensure minimum voltage drop.
- Only three-core cables $\geq 6\text{mm}^2$ should be used (in accordance with local requirements).
- Use protection devices, and the selected circuit protection device must integrate a suitable residual current device (RCD) and a corresponding electrical load over-current protection device.

Power supply cables

NOTE: Consult an electrician to ensure installation complies with local regulations.

7kW: Three-core cables that can carry 230V single-phase 32A (please use $\geq 6\text{mm}^2$ three-core cable).

Cable connection

The connection uses phase wires L(live wire), N (neutral wire) and PE (ground wire). The phase voltage between the live wire and the neutral wire should be 230V.



WARNING: Before using this product, read the instructions thoroughly. Before installing a charger, be sure to determine the type of connection of the available power supply. If you are not sure about the available connection type on the service panel, consult an electrician or contact a PINGALAX technician for assistance.

Note: Please consult a local electrician or PINGALAX technical personnel so as to choose cables suitable for the current specification of the charger.

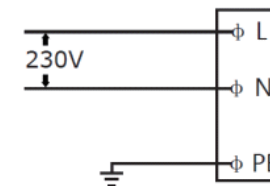

Requirements for circuit breakers

Check the distribution panel or breaker box to determine the type of upstream breaker required and to determine the amperage available at the installation location.

Choose the best location for chargers

Make sure the parking location is in range of the charging cable. The charger should be located in:

- Enclosed garages, on the vehicle charging port side.
- Space that is well ventilated. Avoid installing in closed boxes, avoid high-power electrical appliances.
- When the installation method is wall-mounted, it is recommended to be mounted 1m-1.5m above the ground.
- Positions that should allow easy observation of indicators and convenient operation.
- Environment that is clean.
- Environment that is less than 2km in altitude, with average humidity of 5%~95%RH and ambient temperature of -30°C~+50°C.

Note:

1. The charger can be used outdoors, but it is not designed to be completely immersed in liquid. Rainproof facilities are recommended, but not mandatory.
2. It is advised to set up a canopy (outdoor installation), a camera, and a fire extinguisher on site, which can effectively prolong the service life of the charger, avoid malicious damage to the charger and ensure timely and effective elimination of danger.
3. Live electric equipment such as EV chargers and distribution boxes need to be pasted with obvious anti-shock signs.
4. For better user experience, the distance between the edge of the parking spot and the outer edge of the charger should be more than 0.5 meters, and the arrangement of the charger should not hinder charging and passage of other vehicles.

precautions

- The installation of EV chargers must avoid gas pipes, water pipes and sewage pipes.
- The inlet conduit can be routed along the floor or the lower edge of the wall, or routed from the ceiling, and then install the charger.

Note: The word "conduit" in this manual refers to the protective tube for the power cables. The cables can be enclosed in a protective sheath instead of a conduit.

Below are some additional guidelines:













- The conduit opening size (outer diameter) is 25mm/32mm.
- Please use a suitable circuit breaker. Each charger needs to be powered with an independent circuit breaker in the power distribution cabinet. For a 7kW AC EV charger, the power distribution cabinet needs to be equipped with a 40A/2P miniature circuit breaker. The PE wire must be connected from the grounding bar of the power distribution cabinet, and a special cable terminal must be fixed at the stripped cable.
- The conduit should not have perforations, cracks or obvious unevenness, and the inner wall should be smooth.
- Metal cable conduits should not be severely corroded, and plastic cable conduits should have adequate protection characters.

Conduits with sufficient strength should be used when directly buried in places subject to mechanical damage or greater stress.

Installation (Wall-mounted)

Check the inside of the carton

Parts and accessories included in the shipping carton can be used and installed in accordance with the above instructions, and are also applicable for this manual. If any parts or accessories are damaged or missing, please contact us.

Item	Model	Illustration	Quantity	Remark
EV Charger	RACE series		1	
Charging connector and cable (already fixed)	5m (default)		1	
Hanger			1	Wall-mounted
Post			1	Post-mounted
Charging IC card			2	Stand-alone model with card reader
User manual			1	
Factory report			1	
Certificate			1	
Cross recessed countersunk head tapping screw	M5*60mm		6	Wall-mounted
Cross recessed countersunk head tapping screw	M5*110mm		2	
Plastic expansion sleeve	φ8mm*60mm		8	
Cross recessed countersunk head tapping bolt	M4*8mm		4	Post-mounted
Cross recessed countersunk head tapping bolt	M6*25mm		2	
Cross recessed hexagon bolt	M6*80mm		2	
Expansion bolt	M10*100mm		4	

Installation Instruction (Wall-mounted)

Required tools and materials

Before installing the charger, the following tools and materials need to be prepared:

<ul style="list-style-type: none"> Pencil or marker 	<ul style="list-style-type: none"> Torx Allen wrench (T10)
<ul style="list-style-type: none"> Leveling instrument 	<ul style="list-style-type: none"> Conduit (conduit diameter depends on the cable size and structure)
<ul style="list-style-type: none"> Range finder 	<ul style="list-style-type: none"> Wire clip (configure according to the conduit model)
<ul style="list-style-type: none"> Wire stripper 	<ul style="list-style-type: none"> Three-core cable (6mm²)
<ul style="list-style-type: none"> Electroprobe or digital multimeter (for measuring the AC voltage at the installation site) 	<ul style="list-style-type: none"> Hammer
<ul style="list-style-type: none"> Wrench 	<ul style="list-style-type: none"> Electric driller and drilling bits
<ul style="list-style-type: none"> Cross screwdriver 	

Note: PINGALAX advises shielded cables to avoid potential interference.

Wall opening

Install the charger body following the instructions shown in the figure below:

➢ Take the mounting hole positions on the back of the charger body as reference, mark the positions on the wall for the expansion screws.

- Use a leveling instrument to make sure the marks are vertically aligned.
- The position to install a charger should be at a maximum distance from the ground of no more than 150cm. If installed indoors, the minimum height is 100cm, and if installed outdoors, the minimum height is 120cm (the above data are for reference only).

NOTE: Any reasonably foreseeable influence should be considered and avoided when installing, such as moisture, uneven walls, water, hollow walls, etc.

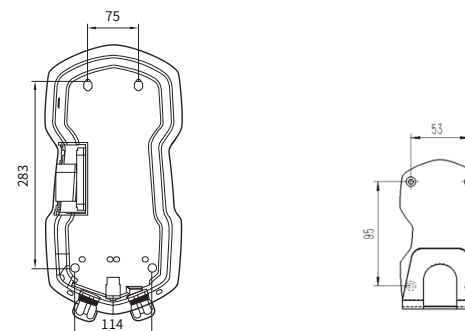

Installation (Wall-mounted)

➤ Take the charger body as reference, mark the installation position of the hanger at a distance of 200mm-500mm from the bottom edge of the charger and 200mm-400mm from the right side. (for reference only).

● Use a leveling instrument to make sure the marks are vertically aligned.

NOTE: It is important to choose the mounting position and the minimum and maximum height for the backplate carefully. Any reasonably foreseeable influence should be considered and avoided when installing.

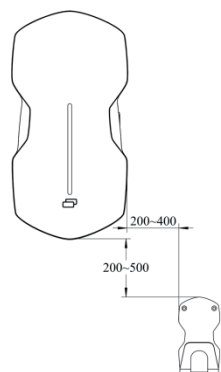

Installation schematic diagram (wall-mounted)

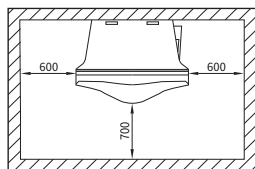

➤ Drill the marked positions on the wall with an electric driller in diameter of 10mm and depth of 60mm. Put the expansion sleeves in the holes and fix properly.

➤ Tighten the 2 screws (M5*60mm) on the upper end of the charger body, leaving 5mm-8mm exposed for the mounting holes on the upper end of the charger body.

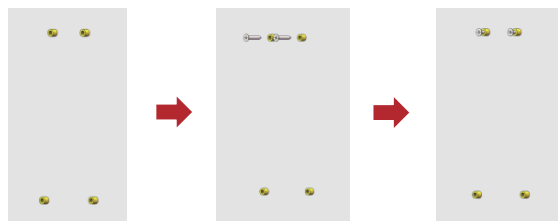

14

Installation (Wall-mounted)

Mount the charger

➤ Remove the 2 screws at the bottom of the outer decorative cover of the charger and take off the outer decorative cover. Hang the charger on the pre-fixed screws through the mounting holes at the upper back of the charger body.

➤ Adjust the exposed length of the screws according to the tightness after hanging.

Note: After removing the decorative cover, be sure to protect the charger from any scratch or damage.

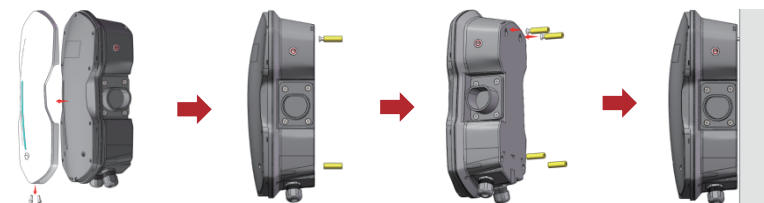

➤ Insert 2 screws (M5*110mm) into the two holes under the charger body cover, align them with the mounting holes on the wall, and tighten the screws.

Note: 1. After installation, it must be able to support a weight of 20kg (reference value).

2. Pay attention to the mounting direction.

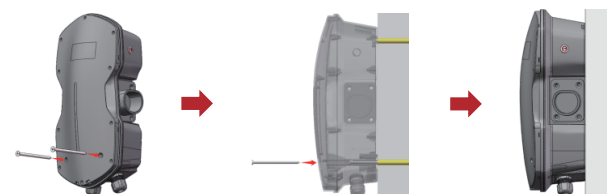

➤ Align the hanger with the pre-drilled mounting holes, tighten the four screws (M5*60mm) of the hanger to install the hanger.

Note: The rack must be able to support a weight of 20kg (reference value) after installation.

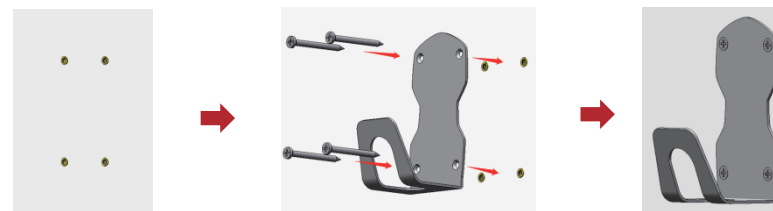

15

Installation (Post-mounted)

Post foundation and site selection

Outline of the post

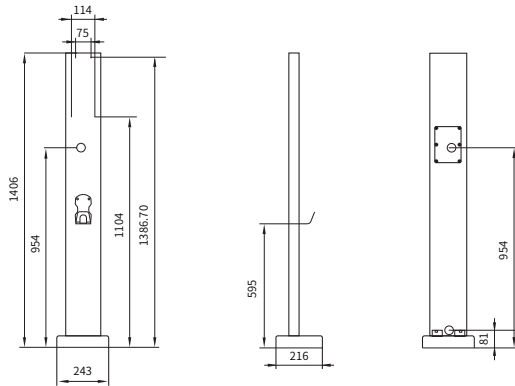

Installation schematic diagram (post-mounted)

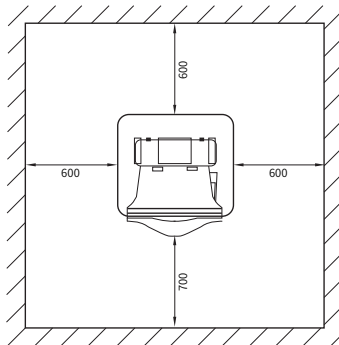

Dimensional drawing of the cable inlet holes and the anchor bolt holes

Installation (Post-mounted)

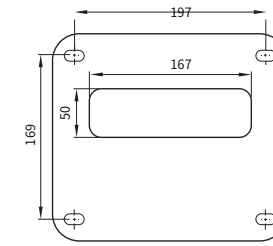

Follow the instructions below to wire and install the post:

(1) 3 inlet methods optional: the bottom inlet method, upper back and lower back inlet methods. The post must be placed vertically on the cement foundation or ground (the ground needs to be hardened), and mounted with anchor bolts or expansion screws.

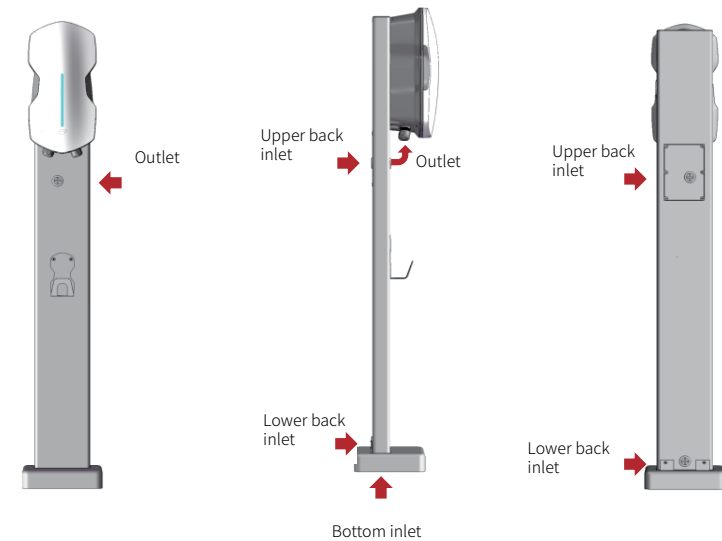

(2) Users can choose the installing method of anchor bolts or expansion screws according to the mechanical strength required by the local climate conditions. In typhoon areas, the charger should be mounted with anchor bolts in cement foundation, this method is more stable to ensure the mechanical strength compared with the normal expansion bolt. Install the post with 4 M10 anchor bolts, and the allowable tilt is 5° in any direction vertically.

Installation (Post-mounted)

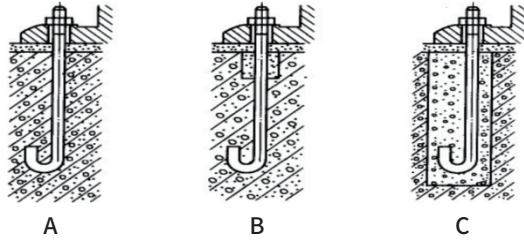

Schematic diagram of anchor bolt installation

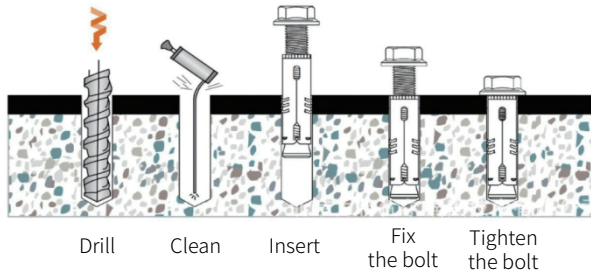

Schematic diagram of expansion bolt installation

(3) The cement foundation for the post depends on the site conditions, the bearing layer of the foundation is the old soil layer, and the characteristic value of the bearing capacity of the foundation shall not be less than 150kpa. In case of over-excavation, C15 concrete shall be used to ensure the foundation be at the designed bottom level, and the foundation itself shall be cast with C25 concrete, which requires one-time pouring, and construction joints are not allowed on the surface. The size of the foundation for post mounting should be slight larger than the size of the post base plate. The length*width should not be less than 343*316mm, and the foundation height is recommended to be 200mm to ensure that the post is completely placed on the foundation to prevent flooding, and to ensure that the height allows convenient operating. The size of the cement foundation should not be too large to avoid inconvenience or users standing on the foundation causing damage to the foundation and danger.

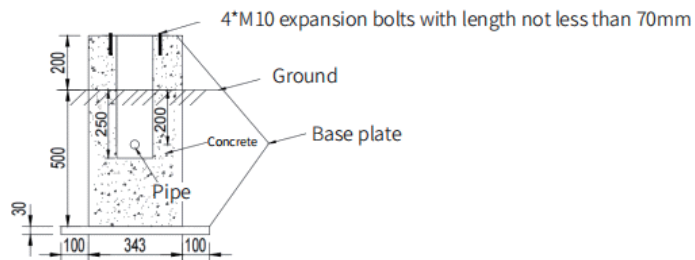

Installation Instruction (Post-mounted)

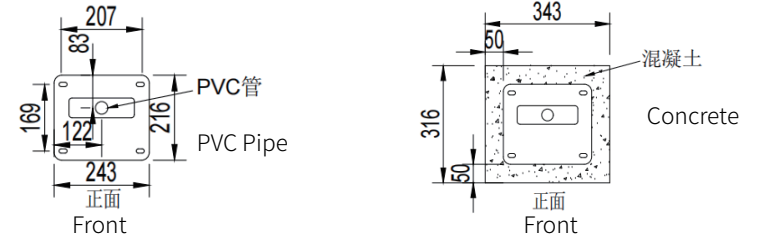

Schematic diagram of foundation opening

Post installation

➤ Use the base plate of the post as a reference to mark the installing positions for the expansion bolts on the ground.

● Use a leveling instrument to make sure the post is vertical to the ground.

NOTE: Please be sure to choose the post position carefully, and avoid any reasonably predictable influences during installation, such as places like: marsh land, sandy soil, damp, salt beds, etc.

➤ Drill the marked placements on the foundation or ground, put the expansion bolts (M10*100mm) into the holes and remove the screw nuts, spring and pads. If you have the bolts embedded already, you can install the post directly.

➤ Remove the cover on the back of the post and detach the decoration cover on the base.



➤ If the power and network cables (network cables are required for ethernet version) are pre-buried underground, you need to firstly put the cables inside the post from the opening at the square base bottom and pull the cables out from the outlet before installing the post.

➤ Place the post on the bolts (expansion bolts or embedded anchor bolts), fix the pads, springs and nuts, and tighten them with a wrench.

● Use leveling instruments to ensure the post be set vertically.

➤ Place the decorative base cover back and tighten the screws.

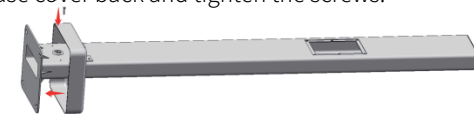

➤ Select the inlet method for the power and network cables (network cables are required for ethernet version).

Installation (Post-mounted)

(1) If the cables are pre-buried underground, use the bottom inlet method.

- Put the power and network cables (network cables are required for ethernet version) into the post through the square inlet at the bottom of the post.

- Then pull the cables out from the circular outlet on the middle front of the post body.

(2) If the cables are routed from the edge of the wall or ground surface, use lower-back inlet method.

- Put the cables (network cables are required for ethernet version) into the circular inlet at the lower back of the post.

- Then pull the cables out from the circular outlet on the middle front of the post body.

(3) If the cables are routed from the ceiling to the post, use the upper-back inlet method.

- Put the power and network cables (network cables are required for ethernet version) into the circular inlet on the back of the post.

- Then pull the cables out from the circular outlet on the middle front of the post body.

- Arrange the power and network cables (network cables are required for ethernet version), fix the plate back to the back of the post, and tighten the screws.

- Install the charging connector holder. Align the holder with the mounting holes on the middle front of the post, and tighten the screws to complete the post installation.

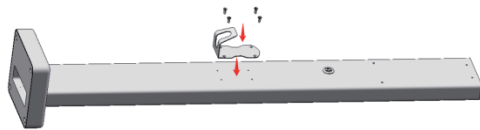

Install the charger

- Tighten the 2 screws (M6*25mm) on the upper front of the post. Approximately 5mm-8mm should be exposed for the mounting holes on the upper end of the charger body

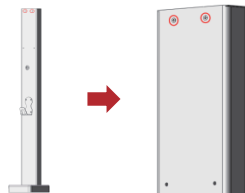

NOTE: 1. After removing the decorative cover, it is necessary to protect it from any scratches or damage.

Installation (Post-mounted)

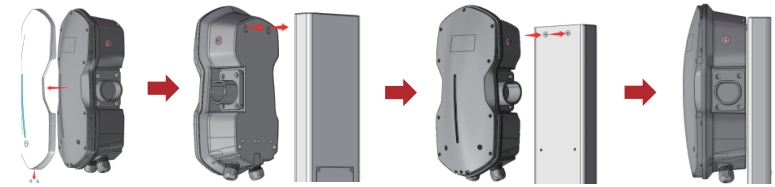

2. Insert 2 screws (M6*80mm) into the two holes under the charger body cover, align them with the mounting holes of the post, and tighten the screws.

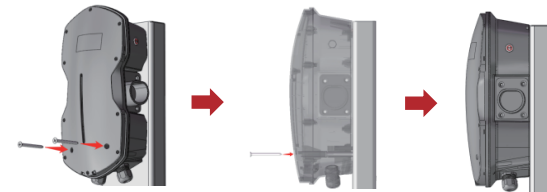

Installation (Cable connection)

Connect the cables

If there is an external cable for input power, just connect the cable to the circuit breaker for power input.

If the charger is not equipped with an external power cable for power input, please connect the cables according to the following instructions.

NOTE: Please consult a local electrician to select cables suitable for the required current of the wall-mounted EV charger.

NOTE: It is the installer's responsibility to ensure that grounding is in accordance with the installation specifications.

NOTE: For single-phase cables, terminals should be connected to L (Live), N (Neutral), and PE (Earth) wires.



WARNING: Do not connect the power cables until you have thoroughly read and fully understood all of the information presented in chapter 3.4 for power cables. Please consult an electrician or contact our technicians for help if there's any question.

- Detach the upper cover in charger body (10 screws).

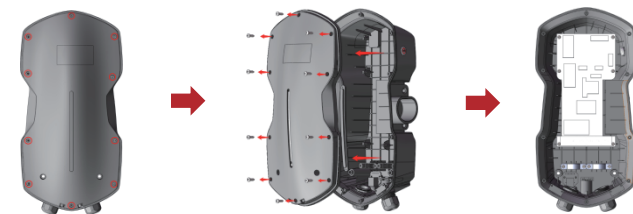

Installation (Cable connection)

> The power cables are three-core cables. They are marked as L (Live), N (Neutral), and PE (Earth) with different colors. Crimp and connect the cables with copper terminals.

● Strip the cables, and the stripping length is between 35mm-45mm.

● To connect the copper terminals, the cables need to be striped, and the stripping length is between 6mm-10mm.

> The cable gland on the bottom left of the charger box is the power cable inlet. Detach the cable gland head on the bottom left of the charger box, put the cable gland head on the power cable, align the gland head and route the cables through the cable gland on the bottom left of the charger.

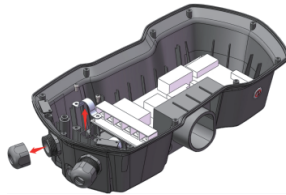

> Open the connection area cover, take out the screws for L (Live), N (Neutral), and PE (Earth) wires and put the wires into the copper terminals, and then tighten the screws and fix the cover back.

> Tighten the cable gland head on the cables with a torque wrench, fix the cover for wire connection area on the back of the charger.

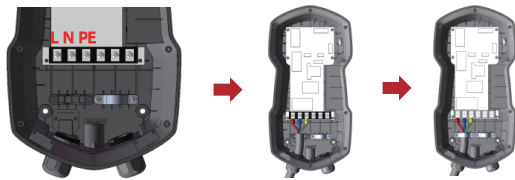

Connect network cables (Ethernet version only)

Connect the network cables through the ethernet port on the mid-bottom of the charger body.

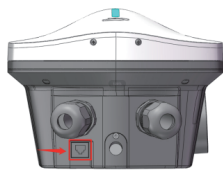

Installation (Cable connection)

Install SIM card (4G version only)

|| If the 4G version charger is not with a SIM card, please follow the instructions below to install the SIM card.

> Locate the 4G communication module on the upper right side of the control board in the charger body, find the SIM card slot, and install the SIM card.

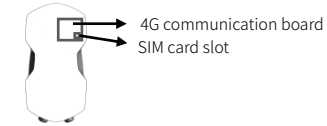

> Press and hold the card slot cover, slide it in the direction of the arrow, and then open the card slot cover.



> Face the side of the SIM card with the chip down, align it with the card slot as shown below.



> Reset the SIM card slot cover back.



DIP Switch Description

|| If set the output power of the charging post, please follow the instructions below (default 4 dip switches are off).

> Determine the position of the stake dip switch and set it according to the actual needs.

Switch1	Switch2	Switch3	Switch4	Output current/power
OFF	OFF	-	-	32A/7kW
ON	OFF	-	-	24A/5.2kW
OFF	ON	-	-	16A/3.5kW
ON	ON	-	-	N/A

Installation (Cable connection)

Install the charger body

- ▮ If equipped with an external power cable, you only need to install the charger decorative cover. If the charger is not equipped with an external power cable, please install the machine cover first, and then install the decorative cover onto the charger.
- Install the machine cover on the bottom shell of the charger body, and tighten the screws on the cover (10 M3 torx anti-theft pan head screws with pin slots).
- Fix the decorative cover to the EV charger and tighten the two screws at the bottom with a screwdriver.

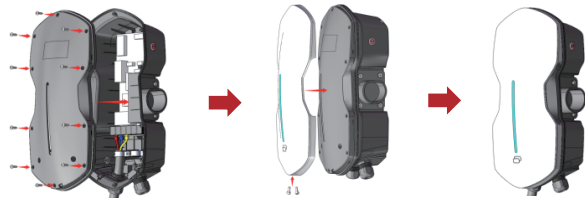

Level the output cable (Charging connector)

- Wind the charging cable neatly on the holder.
- Detach the cover of the charging connector and plug it into the charging connector holder.

Check before use

- After the installation is completed, the commissioning personnel should check whether the wires are connected correctly, whether the fasteners are loose or falling off, whether the wiring harness, terminals and other connections are firmly connected. Before powering on, check whether there is short circuit for the inlet cables with a multimeter. If any problem is found, it must be corrected in time. It is necessary to check again to make sure there is no problem and then power it on. After starting, check whether there is fault alarm, and correct it in time to ensure normal performance after powering on.
- It is recommended to use a megger to test the insulation resistance before powering on the main circuit, and turn it on only after the insulation requirements are met.



Warning: It is necessary to check whether each component is well connected.
NOTE: When conducting the insulation test, the main inlet cable should be detached and all the switches should be disconnected.

Power on

After checking and finding all components in order, you can turn on the power supply.

Wall-mounted/post-mounted AC EV charger

RACE

Series AC Charger

How to Use the Charger

Appearance introduction

RACE series AC EV chargers and accessories:

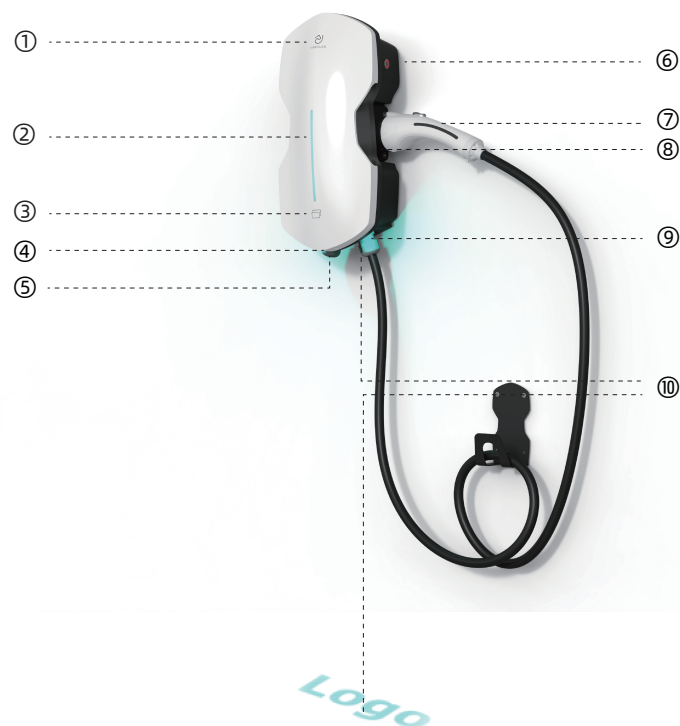

① Logo	⑥ Reset button
② Status indicator	⑦ Charging connector
③ Card reader	⑧ Connector holder
④ Ethernet port	⑨ Ambient light
⑤ Power input cable	⑩ Logo spotlight

How to Use the Charger

Get ready to charge

➤ When the power is on, you will hear "beep" sound (twice) and the status indicator will be turned on (white) indicating that the power is on and the device starts normally.

NOTE: If it is a network version (Bluetooth, Ethernet, WIFI or 4G) charger, it can be used only after being connected to the server.

➤ Plug the charging connector into the AC charging adapter on the vehicle to charge, and the status indicators will flash (green).

Card scanning

➤ Swipe the IC charging card in the sensor area, and if you hear a "beep" sound (once), means the card is read successfully.

NOTE: If charging is not started after swiping the card, the status indicator (red) will flash 5 times.

NOTE: The IC cards for network version chargers need to be credited before using (If the charging IC card number is the same as the charger number, there is no need of credit, and the card can be used directly). If you need to top-up your card, please contact the station operation personnel or PINGALAX.

➤ After the card is successfully read, the charger will automatically start charging, and the status indicator will be in breathing mode (green).

➤ When fully charged, the charger automatically ends charging. When you hear a "beep" sound (2 beeps), the status indicator light will be solid blue. After the connector is drawn, the status indicator light will return to white.

➤ Swipe the charging IC card again, and the charger will automatically end charging. When you hear a beep (3 beeps), the status indicator light will be in blue. After the connector is drawn, the status indicator light will return to white.

NOTE: When the charger is in normal operation, please do not disconnect the power supply, press the Reset button or pull out the charging cable at will.

NOTE: When using the charging IC card to end charging, please use the same charging IC card.

App control

➤ Download PINGALAX App

Download the app by searching "PINGALAX" in app stores or scan the QR code below:

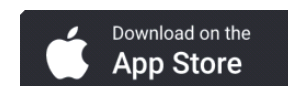

How to Use the Charger

➤ Add new device

Turn on the bluetooth of the mobile phone to add device or click the "+" in the upper right corner on the home page of the app to add device

➤ Device list

EV chargers that are successfully connected will be displayed on the "Device List" page. You can view the connected devices and their status on this page.

➤ Device control

Enter Device Control by tap on the connected devices.

This page will display the real-time status of the EV charger, including idle, connector plugged, charging, timing, charging completed and fault. In idle and plugged-in states, you can choose between Scheduled Charging and Plug & Charge modes.

Through Scheduled Charging, you can set a time to schedule charging;

With Plug & Charge, the charging will start upon plugging of the connector.

➤ Schedule charging

Through Scheduled Charging, you can set the start time, stop time and repetition. If you don't want charging to stop at a scheduled time, you can cancel the stop time.

➤ In charging

While charging, you can view charging data in real-time, including start time, charging power, charging time, real-time current and charging capacity. You can end the charging process at any time by tapping End Charging.

➤ Fault

If your charger is in a faulty, you can tap on the fault details for help and instructions.charging in time.

➤ Charging complete

When charging is complete, you can view the charging quantity, duration, start time, and end time.

➤ Charging record

You can enter the "Historical Charging Record" page by tapping the first icon in the upper right corner of the "Home Page". You can see the latest 20 charging records on this page.

➤ Parameter setting

You can enter the "Settings" page by clicking the second icon in the upper right corner of the "Home Page". You can change the device name, set the maximum charging current and view the detailed specifications of the device on this page. By clicking "Unbind", you can disconnect the app from the charger.

Note: During the charging process, it is prohibited to press the reset button at will. If a dangerous situation occurs, please press the reset button in time to terminate charging.

Power setting

➤ This charger supports charging power setting, and is defaulted at the maximum power output. If you need to set it, please check the "DIP switches introduction" in Page 23.

Trouble-shooting and Maintenance

Failure description

Failure description	Indicators response (charging)	Indicators response (not charging)
Not grounded	Flash once in red and blue, 2s interval	-
Reverse connection of L (live) wire and N (neutral) wire	-	Flash twice in red, 2s interval
Reset button	Press the Reset button once: stay on in blue Long press: Flash 3 times in red and blue, 2s interval	Press the Reset button once: flash once in red and restore Long press: Flash 3 times in red, 2s interval; No response if long press after charging connector connected
Current leakage	Flash 4 times in red and blue, 2s interval	-
Overcurrent	Flash 5 times in red and blue, 2s interval	-
Overvoltage	Flash in red and green	-
Undervoltage	Flash in red and green	-
Overtemperature	Flash 8 times in red and blue, 2s interval	-
Meter	Flash 4 times in red and blue, 2s interval	-
Relay	-	Flash 10 times in red, 2s interval (relay not in operating)
CP detection error	Flash in red	-
Server not connected	-	Flash 12 times in red with 2s interval when swiping the card or scanning the code

Maintenance

In order to ensure the normal service life of the charger and reduce the risk during operation, it is recommended to maintain within specified period, check the table below:

NOTE: The maintenance of the charger must be carried out by professionals, and qualified and safe maintenance tools should be used.



Warning: To ensure safety, please disconnect the power before maintenance

Trouble-shooting and Maintenance

Item	Content	Period
Appearance inspection	Check whether the appearance of the charger body and the charging connector is in good condition	irregular inspection (The longest period should not exceed 6 months)
Dust removal	Remove the dust on the surface of the charger and the cable, and remove the dust inside the port of the charging connector	
Check the signs	Check each label, and replace it immediately if any sign that is peeled or blurred	6 months
Internal inspection of charger body	Check whether the components of the charger are in good condition, and whether the screws and bolts are corroded or loose	6 months
Whole machine characteristics	Check whether the functions of the charger are in normal condition	6 months
Reset button test	In the charging state, press the emergency button and check whether the charger stops charging	1 month
Leakage circuit breakers	Check whether the circuit breaker is effectively disconnecting the electrical connection	6 months
	Check whether the leakage circuit breaker is effective for leakage protection	1 month

Note: Keep the maintenance records for each time, which can be used as a reference for equipment replacement.

Note: The maintenance period can be determined according to the using environment of the charger (less than or equal to 6 months). If the charger is installed in a relatively harsh environment, the maintenance period should be shortened.

Reliability Terms

General clause

In addition to the following terms and restrictions, the warranty service of the company's products includes necessary refunds, repairs and replacements for the manufacturing defects of the chargers that manufactured and provided by us within 12 months (calculated from the date of providing the purchase invoice to the customer) of normal use. However, the warranty service does not apply to direct or indirect damage or failure caused by normal wear, abuse, misuse, neglect, accident, improper installation, using, maintenance, storage or transportation, including but not limited to:

- Failure to follow the instructions in this manual of our charger;
- External factors: including but not limited to the failures or damages resulted from physical hitting to the charger body, electrical wiring, junction boxes, circuit breakers, sockets or power outlets, and the damages resulted from environmental or natural disasters (including but not limited to fire, earthquake, flood, lightning and other environmental conditions);
- General damages to cosmetic or paint, including chipped, scratched, dented or broken paint;
- Did not contact us after discovering the defects contained in this "Limited Quality Warranty for Charging Equipment";
- The charger or any parts and accessories been repaired, modified, or installed or used by unauthorized and unlicensed individuals or parties;
- Lack of or improper repair or maintenance, including use of non-genuine accessories or parts, and commercial use.

Liability Clause

Although it is not required to do all services or repairs at PINGALAX service center or PINGALAX authorized service stations, lack of or improper service or repair will void this warranty or cause the stated repair services to be excluded from the scope of warranty. PINGALAX service centers and PINGALAX authorized repair shops can supply professional training, technicians, tools and materials related to PINGALAX chargers, in specific cases, these centers and shops are the only spots that employs authorized or licensed personnels or are authorized or licensed to operate PINGALAX chargers. We strongly recommend that you do all maintenance, service and repair works at PINGALAX service centers or the PINGALAX authorized service stations to avoid invalidation of this warranty or cause the above maintenance duties to be excluded from the warranty scope.

Limitation of Liability

This clause is the only express warranty offered by PINGALAX to you. The express and implied warranties and conditions arisen from applicable laws, regulations, or other current rules, including but not limited to the implied warranties and conditions of merchant ability or fitment for particular purposes, the implied warranties and conditions of durability, or any warranties and conditions arisen from trade practices, are disclaimed to the fullest extent permitted by law, or limited to the duration of the warranty period. To the fullest extent permitted by law, our sole remedy for defects within the warranty scope is necessary repair and/or replacement of parts, reworked parts, or remodeled parts. To the maximum extent permitted by law, the liability of this warranty service clause is limited to the reasonable price range for repairing or replacing the relevant PINGALAX chargers and shall not exceed our suggested retail price. When necessary, PINGALAX may replace parts with similar types and qualities, including non-original manufacturer parts, refurbished parts, or remodeled parts.

Any liability for defects in this warranty service clause shall not exceed the fair market price of the relevant PINGALAX chargers before the defect is discovered. In addition, the total amount of compensation under this warranty service clause shall not exceed the price you paid for the chargers. PINGALAX has the right to authorize any individual or entity to generate any other obligations or responsibilities related to this warranty service term on its behalf. Subject to legal regulations, PINGALAX has the full discretion to decide whether to repair or replace parts, or use new, refurbished, or modified parts. Subject to legal regulations, PINGALAX hereby declares that it shall not be liable for any indirect, incidental, special, or consequential damages related to PINGALAX chargers, including but not limited to transportation costs to and from PINGALAX authorized service centers, loss of time, loss of income, loss of use, personal or commercial property damage, inconvenience or aggravation, mental anguish or harm, business losses (including but not limited to loss of profits or revenue), tow fees, public transportation fares, vehicle rental fees, service call fees, fuel costs, accommodation expenses, damage to towing vehicles, and incidental expenses such as call, fax, and postage fees.

Bounded by laws and regulations, compensation claims are based on contractual provisions, breach of warranties and conditions, misrepresentation (whether negligent or otherwise) or claims compliance with law or precedents, and the above limitations and exclusions shall apply, even if we are aware of the possibility of such damage or such damage can be reasonably predicted.

Product Warranty

Product warranty card

- 1, The warranty period is calculated from the date of installation.
- 2, During the warranty period, if the product cannot perform normally due to poor quality, poor installation by the installation team designated by PINGALAX, or fails from normal use according to the user manual (determined by the company's staff), PINGALAX will repair free of charge.
- 3, Non-warranty scope:
 - 1) Warranty card and valid proof of purchase are not available.
 - 2) Failure or damages caused by improper use, unauthorized repair, disassembly and shifting after installation.
 - 3) Failure or damages caused by transportation, moving, or falling after purchase.
 - 4) Failure or damages caused by other inevitable external factors (irresistible factors such as natural disasters and man-made disasters).
- 4, Product appearance, vulnerable and consumable parts and accessories are not under the warranty: Vulnerable and consumable parts and accessories include: (charging connector, status indicator light, ambient light, spotlight).
- 5, Please keep this card properly, and it is valid only when it is presented together with the official purchase invoice or formal purchase contract when maintenance is required.

Warranty Card

Product Name: _____

Product Model No.: _____

Factory Number: _____

Production Date: ____ D ____ M ____ Y

Client Name: _____

Contact: _____

Client Address: _____

1、Warranty Content: _____

After Sales: _____ Client Signature: _____ Satisfied Dissatisfied

2、Warranty Content: _____

After Sales: _____ Client Signature: _____ Satisfied Dissatisfied

3、Warranty Content: _____

After Sales: _____ Client Signature: _____ Satisfied Dissatisfied

RED Declaration of Conformity (DoC)

Unique identification of this DoC:

We,

Chongqing Pingchuang Institute of Semiconductors Co., Ltd.

No.1 Hongyu Avenue, Biquan Street, Bishan District, 402760 Chongqing City, PEOPLE'S REPUBLIC OF CHINA

declare under our sole responsibility that the product:

product name: 7kW AC EV Charger(J4)

trade name: PINGALAX

Model: RACE-EU7/230

relevant supplementary information:

(e.g. lot, batch or serial number, sources and numbers of items)

to which this declaration relates is in conformity with the essential requirements and other relevant requirements of the RED (2014/53/EU).

The product is in conformity with the following standards and/or other normative documents:

HEALTH & SAFETY (Art. 3(1)(a)): EN IEC 61851-1:2019, EN 62311:2008, EN IEC 62311:2020

EMC (Art. 3(1)(b)): EN 301 489-1 V2.2.3:2019, EN 301 489-3 V2.3.2:2023, EN 301 489-52 V1.2.1:2021, EN IEC 61851-21-2:2021

SPECTRUM (Art. 3(2)): EN 300 330 V2.1.1:2017, EN 301 908-1 V15.1.1:2021, EN 301 908-13 V13.2.1:2022

OTHER (incl. Art. 3(3) and voluntary specs): N/A

Other Union harmonization legislation (where applicable): N/A

Accessories: N/A

Software: N/A

Technical file held by: **Chongqing Pingchuang Institute of Semiconductors Co., Ltd.**

Place and date of issue (of this DoC): No.1 Hongyu Avenue, Biquan Street, Bishan District, 402760 Chongqing City, PEOPLE'S REPUBLIC OF CHINA 2024.4.17

Signed by or for the manufacturer:

(Signature of authorised person)

Name (in print):

Title: Section manager

Hereby, Chongqing Pingchuang Institute of Semiconductors Co., Ltd., declares that this RACE is in compliance with the essential requirements and other relevant provisions of RE Directive 2014/53/EU.

A copy of the full DoC is attached.